

100C6 Froet Drain® Roof Drain Submittal

The Froet Drain® bi-functional roof drain is to be used in any flat roof construction. All drain parts are cast iron with the exclusion of the overflow riser pipe which is steel. Connections are all no hub.

Installation Tips:

The extensions are to be used to provide clearance of the primary outlet when used with thicker decks and/or thicker insulations. Froet Industries recommends that a sump be created with the insulation to promote flow and prevent ponding due to the height of the drain ring. Any ponding at the roof drain is likely to increase the frequency of the drain strainer becoming obstructed with debris. The roofing contractor needs to install roofing membrane so as to not obstruct the primary sump area

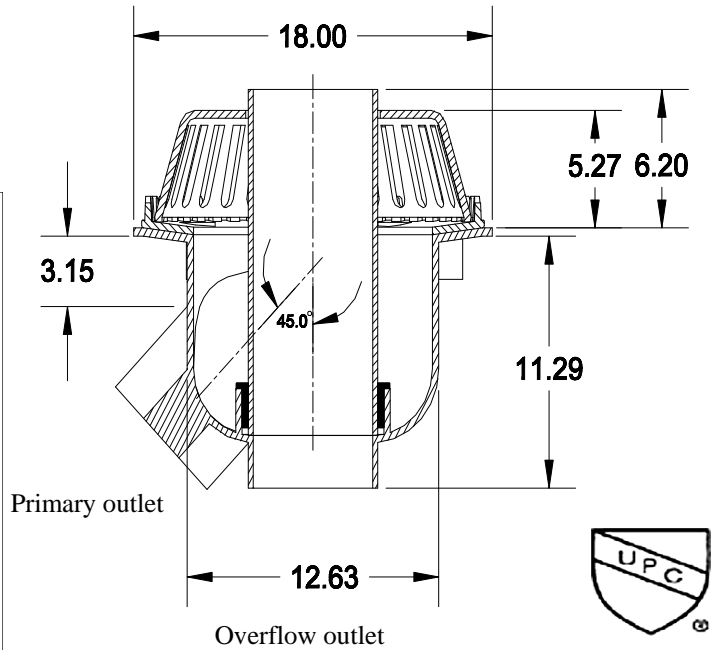

Project Options

LP	Low Profile
DC	Deck Clamp
DEX-2	2" Extension
DEX-4	4" Extension
DEX-6	6" Extension
OFS	Overflow Strainer
DP	Flat Drain Pan
SP	Sumped Drain Pan
DMP	Deck Mounting Plate
FR	Finishing Ring
IG	IRMA Roof Guard
CFW	Control Flow Weir
VP	Vent Pipe

Standard roof drain supplied with 5 inch high primary strainer and 6 inch high overflow.

Low Profile roof drain supplied with 3 inch high primary strainer and 4 inch high overflow.

Please note: Overflow strainer not included with base drain. The OFS designation must be in part number to include overflow strainer

Project name: _____

Contractor: _____

Gen Cont: _____

Design Firm: _____

Froet Industries LLC 1741 Industrial Drive Sterling Illinois 61081
 ph. 815.626.7922 fx. 815.626.0702
 www.froetindustries.com